

Report: CR-2004/16

A protocol for the establishment and operation of LTPP sections

Authors: D Jones and P Paige-Green

PREPARED FOR:

Gautrans
PBag x3
LYNN EAST
0027

PREPARED BY:

CSIR Transportek
PO Box 395
PRETORIA
0001
Tel: +27 12 841-2905
Fax+27 12 841-3232

DOCUMENT RETRIEVAL PAGE			Report No: CR-2004/16	
Title: A protocol for the establishment and operation of LTPP sections				
Authors: D Jones and P Paige-Green				
Client: Gautrans	Client Reference No: CR-2004/16	Date: March 2004	Distribution: Client Confidential	
Project No: TIK32	OE2: Infrastructure Engineering		ISBN:	
<p>Abstract:</p> <p>This document describes a protocol for establishment and operation of long-term pavement performance (LTPP) sections, including those linked to HVS tests. This is detailed under the following headings:</p> <ul style="list-style-type: none"> • Linking LTPP to HVS data collection • Management and responsibilities • Site location and establishment • Data collection • Reporting criteria <p>A set of data capture forms is provided.</p>				
<p>Keywords:</p> <p>Long term pavement performance, LTPP, APT, HVS</p>				
<p>Proposals for implementation:</p> <p>None</p>				
<p>Related documents:</p> <p>CR-2003/7: CR-2003/25</p>				
Signatures:				
L Sampson Language Editor	L Sampson Technical Review	B Verhaeghe Prog Manager	Info Centre	P Hendricks Director

TERMS OF REFERENCE

CSIR Transportek was requested by Gautrans to develop a protocol for the establishment and operation of LTPP sections. The terms of reference for the study were to:

- Undertake a literature review on other LTPP studies
- Develop an appropriate protocol linking to the protocol already developed for HVS testing
- Develop appropriate data specifications for monitoring
- Prepare a report detailing the study and the recommended protocol.

DISCLAIMER

1. This report is the property of the sponsor and may be published by them provided that:
 - i) The CSIR is acknowledged in the publication.
 - ii) It is published in full, or where only extracts therefrom or a summary or an abridgement thereof is published, the CSIR's prior written approval of the extracts, summary or abridged report is obtained.
 - iii) The CSIR be indemnified against any claim for damages that may result from publication.
2. The CSIR will not publish this report or the detailed results without the sponsor's prior consent. The CSIR is, however, entitled to use technical information obtained from the investigation but undertakes, in doing so, not to identify the sponsor or the subject of this investigation.
3. The contents of this report may not be used for purposes of sale or publicity or in advertisements without the prior written approval of the CSIR.

TABLE OF CONTENTS

1.	INTRODUCTION.....	1
1.1.	Background.....	1
1.2.	Scope.....	2
2.	LINKING LTPP TO HVS DATA COLLECTION	3
2.1.	Introduction	3
2.2.	Data Collection.....	4
2.3.	Laboratory and Field Testing Requirements	5
2.4.	Experimental Sections	6
3.	MANAGEMENT AND RESPONSIBILITIES.....	8
3.1.	Introduction	8
3.2.	Staffing.....	8
3.3.	Other Resources.....	11
3.4.	Database Management	11
3.5.	Funding	11
4.	SITE LOCATION AND ESTABLISHMENT.....	15
4.1.	Section Location	15
4.2.	Section Numbering	17
4.3.	Section Layout and Marking	17
4.4.	Instrument Installation.....	19
4.5.	Weather Station	20
5.	DATA COLLECTION.....	23
5.1.	Monitoring Standards.....	23
5.2.	Sampling and Reinstatement.....	28
5.3.	Monitoring Program	29
5.4.	Laboratory Testing.....	29
6.	REPORTING CRITERIA.....	35
6.1.	First Level Analysis	35
6.2.	Second Level Analysis.....	35
7.	REFERENCES.....	36
	APPENDIX A: INSTRUMENTATION	38
A.1	Road Surface Deflectometer (RSD)	38
A.2	Multi-Depth Deflectometer (MDD)	39
A.3	Temperature Buttons	42
A.4	Dual Probe Hydro-density Meter	43
	APPENDIX B: REPORTING FORMS.....	46

1. INTRODUCTION

1.1. Background

Long-term pavement performance (LTPP) programmes are established to support a broad range of pavement performance analyses leading to improved engineering tools to design, construct and manage pavements. Most current LTPP programmes focus on the calibration of pavement performance models used in pavement management systems. It is also recognized that the link between accelerated pavement testing (APT) and in-service pavement performance is through LTPP studies. While APT can, and does, provide significant data for analysing and predicting the effects of traffic loading on the performance of various materials, it is not always capable of capturing environmental and other long-term effects. It is only when comparisons of LTPP and APT are available that there will be greater confidence in the interpretation and use of APT results for long-term performance prediction.

Hence the need has long been recognised for establishing LTPP test sections linked to existing and future APT sections, so that the long-term performance of the test pavements can be linked to their performance under APT. However, in South Africa, sustained long-term funding for this type of program has not been forthcoming and the programs have thus never been fully initiated, with LTPP studies mostly being undertaken on an ad hoc basis only. LTPP sections have, however, been identified for calibrating pavement deterioration models for pavement management systems in Gauteng and the Western Cape and are being monitored at routine intervals.

There is renewed interest in linking APT to LTPP worldwide, given the increase in the number of APT facilities and the need for accelerating the implementation of new technologies that will reduce the cost of infrastructure provision and rehabilitation, withstand increasing numbers of axles, axle weights and tyre pressures and minimise traffic disruptions.

In order to ensure that models and pavement design specifications determined from the data collected during APT and/or LTPP programmes are reliable, it is imperative that the data is collected in a systematic, consistent and correlatable manner. Protocols are therefore necessary to ensure that this is achieved.

While a protocol has already been developed for the establishment and operation of HVS test sections for Gautrans, it is now necessary to develop an LTPP protocol that provides a consistent approach to data collection, whether associated with HVS sections or stand alone sections.

This document provides a protocol for the establishment and assessment of LTPP sections and has been developed to provide consistency with data collected from HVS testing.

1.2. Scope

The idea of using LTPP sections to establish a link to real world conditions is not new, and thus this study builds on existing protocols, and, in particular, the FHWA US LTPP and Austroads LTPP/ALF testing programs, which are the most comprehensive LTPP studies that have been undertaken. However, because the South African LTPP sections need to be assessed in terms of pavement performance for pavement management systems, comparison with HVS predictions and general performance for specific assessments, the protocol will be formulated to use South African test methods and, where applicable, providing consistent data related to HVS-type testing procedures.

This protocol is presented under the following sections

- Linking LTPP to HVS data collection
- Management and responsibilities
- Site location and establishment
- Data collection
- Reporting criteria

2. LINKING LTPP TO HVS DATA COLLECTION

2.1. Introduction

HVS testing is an important and useful tool rapidly providing pavement behaviour data. The results of LTPP testing differ in format and probably content. Although these are the ultimate data for inferring pavement performance and as many LTPP sections as possible should be developed, the cost of maintaining and monitoring them is high and significant additional data is available for HVS work.

Any protocol developed for LTPP testing must thus be compatible between the two techniques in order to make optimal use of the available data accumulated from HVS testing.

Although the HVS is a very useful piece of equipment, and gives strong indications of pavement performance, a number of inherent deficiencies affect the outputs. These include:

- HVS testing covers a 1.0 m wide test section with a normally distributed loading pattern. In practice, traffic is not confined to the same one metre and although the distribution is still probably normal, it is expected that the distribution curve is flatter and wider.
- The HVS tests an 8.0 m long section with a uniform load in both directions. In practice, a road would be trafficked in one direction with variable loads. It should be noted, however, that the HVS can test unidirectionally, but the testing time is approximately doubled.
- The HVS operates at a repetitive high load, unlike the varying loads typical on roads
- The relaxation period on the test section is almost constant in the middle of the section, but varies from minimum to maximum near the two ends.
- During the hottest period of the day (probably the most damaging to asphalt roads) the test section is predominantly in the shade of the machine.
- Typical pavement temperature variations during the day are not reflected beneath the machine. It has been shown¹ that the radius of curvature of pavements is lowest during the coolest part of the day due to thermally induced moisture movements.
- The HVS wheel tests the road at a constant and slow speed, unlike a normally trafficked road where vehicles travel at differing speeds.
- The HVS testing period is relatively short and does not take into account fluctuating moisture contents in the pavement structure resulting from seasonal

variation. At the end of the test, the moisture content of the sections is usually artificially raised to what is probably outside normally expected conditions, to induce failure.

- HVS testing primarily tests the behaviour of a pavement structure under a controlled loading regime, whereas LTPP programs assess pavement performance under actual conditions.
- The HVS wheel is not a driven wheel and therefore has potentially different tyre-pavement interaction effects compared with the torque effects of the driven vehicles of heavily laden trucks.
- Although the HVS MkIV has a dynamic capability that provides more testing options, the expected profile and dynamic effects of new roads cannot be predicted during HVS testing and hence a realistic dynamic profile cannot always be simulated by the HVS.

There is no doubt that an understanding of pavement behaviour is the basis for understanding pavement performance. The performance affects the costs of maintaining the road and operating traffic on it. LTPP is the only practical means of linking these two aspects. It is therefore essential that the protocols for HVS testing and LTPP testing ultimately provide comparable information. For direct comparison, monitoring of the same characteristics using the same equipment as far as practically possible should be carried out. The possible use of the data for other applications, such as calibration of HDM models, should be taken into account when planning HVS-LTPP monitoring programs.

The layout and requirements of individual LTPP sections may differ significantly, depending on the specific objective of the assessment. Monitoring should, however, be in line with this protocol as far as possible with additional requirements being satisfied as necessary.

2.2. Data Collection

There is general consensus on the performance characteristics of roads that should be assessed in order to understand the road pavement behaviour in the short-term and performance in the long-term.

Routine field-testing and monitoring of these characteristics, however, has resulted in the development of numerous techniques over the years, these being improved on an ongoing basis. The results obtained from measurements of a single property, but using different equipment or methods, are not always directly comparable (eg RSD, FWD and Deflectograph deflection measurements). For this reason, it is essential that as a

minimum, only directly comparable or well-correlated assessment techniques are used for LTPP experiments.

Specific equipment has evolved to fulfil the measurement need of various behavioural properties during HVS testing. This has often involved expensive research and development resulting in sophisticated equipment fulfilling all the desired needs. The same parameters should thus be assessed in the same way on LTPP sections in order to ensure the required linkage. Additional techniques can be used for specific requirements on LTPP sections to complement the minimum requirements. However, these need to be calibrated against the prescribed techniques. It should be noted that, because of the limited area monitored during HVS testing, certain of these techniques may not be practical over the full area of an LTPP section (eg longitudinal profile).

A precise record of the wheel loading is recorded on every HVS test. In order to accurately relate performance of LTPP tests to that of HVS sections, it is imperative that accurate loading data is also available for the LTPP sections. The installation of permanent traffic recording equipment on each LTPP section is therefore strongly recommended.

The minimum data measurement requirements prescribed for LTPP sections have been partly based on the requirements for HVS tests and are listed in Table 2.1. The number and frequencies of measurement are discussed fully in Section 5 of this document.

With ongoing development in measurement and analysis techniques, it is likely that some of the recommended methods could be improved or replaced during the life of the LTPP sections. It is imperative that any new technique adopted is carefully calibrated against the existing technique on all sections before it is replaced.

2.3. Laboratory and Field Testing Requirements

Where LTPP sections are established in association with HVS tests, the laboratory testing program currently followed for HVS tests should be expanded to include the LTPP test program. These tests will form the basis for comparison with later field tests. The actual tests carried out will depend on the type of pavement and surfacing being tested and the reason for carrying out the test. A testing program should be specified in the project brief.

LTPP sections that are established for other purposes should have testing programs specified in the project brief with the minimum testing requirements shown in Section 5.4.

2.4. Experimental Sections

Monitoring of experimental sections would generally follow a similar protocol, although the experiments may be designed to assess specific characteristics of a new product, material or design philosophy. In these cases, it is often necessary to establish longer sections such that riding quality or maintenance costs can be accurately quantified. It is, however, suggested that a representative 200 m long section within the total experimental section be established according to this protocol.

Table 2.1: Minimum measurement requirements for LTPP sections

Property	LTPP	HVS	Justification for difference
<i>Visual assessment</i>	HDM Calibration guide/ Modified TMH9	Description of cracks	Although TMH-9 is the standard visual assessment procedure, additional information on cracks is captured to allow use of sections for HDM calibration.
<i>Transverse profile</i>	Straight edge & wedge/ electronic straight edge	Laser profilometer	Full lane width is too wide for laser profilometer. Stabilization of measurement datums would also be difficult
<i>Longitudinal profile</i>	Calibrated profilometer	Straightedge	LTPP section is too long to measure with straightedge. IRI measurements can be used for calibration of HDM models
<i>Deflection</i>	FWD, RSD	RSD	FWD used routinely in network analysis in Gauteng
Permanent deformation at various depths	MDD	MDD	-
<i>Density</i>	Dual-probe strata gauge	Dual-probe strata gauge	-
<i>Moisture content</i>	Dual-probe strata gauge/gravimetric	Dual-probe strata gauge	Gravimetric moisture contents will be used to calibrate moisture content on the strata gauge
Pavement temperature	Temperature buttons	Temperature buttons	-
<i>Traffic</i>	Weigh-in-motion	HVS	-
<i>Weather details</i>	Weather station	Weather station	-
<i>Those properties indicated in italics are considered to be the minimum necessary for monitoring LTPP and experimental sections.</i>			

3. MANAGEMENT AND RESPONSIBILITIES

3.1. Introduction

LTPP studies, as the name implies, are long-term and should essentially run for the design life of the road and even through rehabilitation. Therefore in many cases individuals who initiate a study are unlikely to be involved at the end of the service life of the road. For this reason, roles and responsibilities need to be clearly defined and suitable posts identified within the Authority or Agency responsible for the LTPP sections with appropriate additions to job descriptions and key-result areas.

3.2. Staffing

The following minimum staffing requirements are recommended (Figure 3.1). Given that there will, in all likelihood, only be a relatively small number of LTPP sections, responsibilities will probably be incorporated into existing posts.

- Project director
- Project manager
- Field technician
- Technician's assistants
- Database manager

The project director and project manager are Road Authority/Agency posts. If other posts are contracted out, then the contractor should also be required to appoint a project manager to assume responsibility and accountability for their staff and to liaise directly with the Road Authority/Agency project manager.

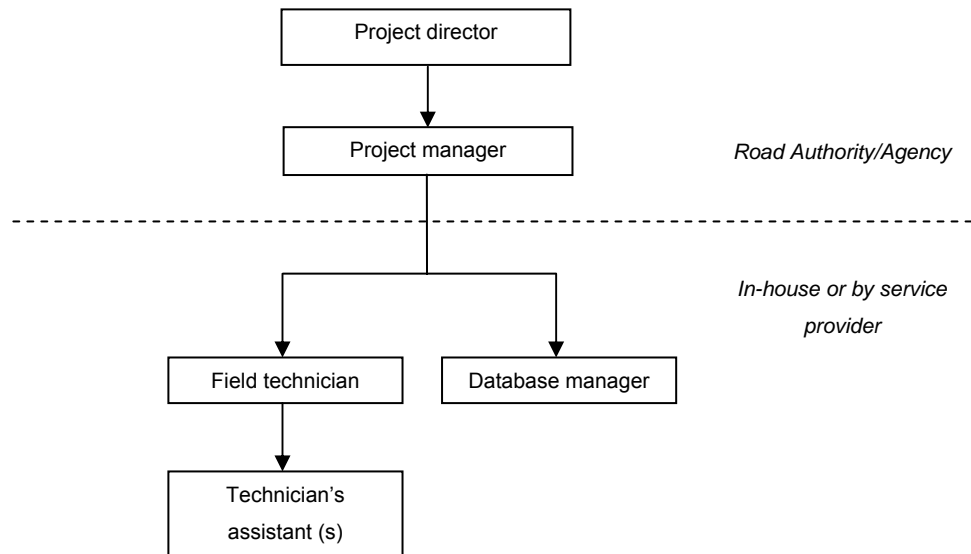

Figure 3.1: LTPP staff organisation chart

3.2.1 Project Director

The Project Director should have the following responsibilities for which he/she should be held accountable:

- Develop a strategic LTPP programme and experimental design
- Authorise the establishment of LTPP sections
- Motivate, justify and ensure sustainable funding
- Overall programme management and accountability
- Quality management of outputs
- Strategic management and implementation of findings
- Industry liaison, coordination and feedback

3.2.2 Project Manager

The Project Manager should report to the Project Director and should have the following responsibilities for which he/she should be held accountable:

- Liaison with Project Director and HVS Project Manager for HVS-LTPP sections
- Site demarcation and establishment
- Site management and environmental, health and safety management for LTPP operation
- Calibration and accreditation of instrumentation, procedures and facilities
- Management of laboratory testing and control sample storage
- Appointment and management of other resources (eg FWD and traffic information)

- Training and calibration of the Field Technician
- Liaison with the Database Manager to ensure that data is useable and in the correct format
- Analysis of results and reporting
- Management of maintenance interventions

3.2.3 Field Technician

The Field Technician should report to the Project Manager and should have the following responsibilities for which he/she should be held accountable:

- Safety of field assistants and road users on site, including traffic control
- Site markings
- Instrumentation
- Routine monitoring and timeous presentation of required results to the Database Manager
- Sampling and laboratory testing
- Ordering of commercial services (eg FWD)
- Reinstatement of sample holes and checking previous reinstatements
- Feedback on changes in appearance and performance

3.2.4 Technician's Assistants

The Technician's Assistants report to the Field Technician and assist in traffic control, site measurements and data capture duties as required.

3.2.5 Database Manager

The Database Manager should report to the Project Manager and should have the following responsibilities for which he/she should be held accountable:

- Timeous and accurate capture of data
- Database maintenance
- Facilitate report printing and distribution in suitable formats
- Ensure long-term availability and accessibility of all records in the database

Given the long-term nature of LTPP programmes, it is recommended that the database is kept in-house (ie at Gautrans) to prevent problems (eg lost data because of computer and software compatibility) associated with switching between contractors.

3.3. Other Resources

Other resources required for the monitoring of LTPP sections that fall under the responsibility of the Project Manager include:

- An accredited laboratory
- Calibrated instrumentation and monitoring equipment as specified

3.4. Database Management

With projects of this nature and the rapid developments in the Information Technology arena, conscientious and regular attention to the entire database will be necessary to ensure that it is always accessible using current hardware and software. Considerable useful information on various road projects collected in the past has been lost or become unusable due to poor or erratic database management. The database must be comprehensively backed up regularly and these backups must always be upgraded when new hardware and software is installed.

The LTPP and HVS databases should be separate but compatible in order that the results from both systems can be directly compared or analysed together.

In order to facilitate the use of the information in the databases by authorised individuals, Internet access should be considered as part of the database development.

Considerable effort has been invested in the development of the database for the US LTPP study and providing access to users via the internet. The database can be accessed at <http://www.datapave.com>.

3.5. Funding

Unless sustainable funding can be guaranteed for an LTPP program, early investment in the setting out and monitoring of sections can be of little ultimate benefit. Many potentially useful experiments that would have gained significantly by long-term monitoring have not produced the desired results because of erratic or no sustainable funding.

In this protocol, the onus for ensuring sustainable funding is placed on the Project Director. This person will require significant support in the form of a long-term contractual agreement that should not be prejudiced by inevitable staff changes.

In order to reach these agreements, it will be necessary to estimate the annual cost of sustaining the program. Table 3.1 lists the typical components of the establishment, monitoring, data capture and administration of an LTPP section, which can be used as a guide, with additions, to facilitate the estimation of costs.

Table 3.1: Typical components of an LTPP monitoring program

Component	Manpower	Units (Days)	Cost (R)	Total (R)	Equipment	Units (No)	Cost (R)	Total (R)	Once-off equipment for program			
									Equipment	Units	Cost (R)	Total (R)
Location and establishment	Project director				MDD	3			Truck	1		
	Project manager				Temp buttons	3			RSD	1		
	HVS engineer				Aluminium tube	9			DCP	1		
	Field technician				Sign boards	2			WIM	1		
	Field assistants				Paint	1			Straight edge	1		
	Travel				DCP points	3			HDM	1		
	S&T				FWD	1			Warning signs (sets)	2		
					Profilometer	1			Cones	50		
					Lab testing	1			Flags	2		
					Truck	1			Tape	2		
					Cold mix	1			Drill	1		
									Auger	1		
	Monitoring	Project manager				Truck	1					
Field technician					DCP points	3						
Field assistants					FWD	1						
Travel					Profilometer	1						
S&T					Cold mix	1						

Component	Manpower	Units (Days)	Cost (R)	Total (R)	Equipment	Units (No)	Cost (R)	Total (R)	Once-off equipment for program				
									Equipment	Units	Cost (R)	Total (R)	
Data capture	Project manager Data manager												
Administration and management	Project director Project manager												

4. SITE LOCATION AND ESTABLISHMENT

4.1. Section Location

4.1.1 Existing Sections

Thirty-seven HDM calibration sections have been identified for use by Gautrans and are currently being monitored on an annual basis. Specific criteria relevant to the selection of HDM calibration sections were followed to develop an experimental design matrix and to identify the sections. A spectrum of South African pavements is represented in the design matrix.

Provision has been made for LTPP sections adjacent to HVS sections at a number of sites. Although no routine monitoring is being carried out on these sections, they could be incorporated into an LTPP program if required.

4.1.2 New Sections

The identification and selection of LTPP sections will depend on the specific criteria and requirements of that investigation. The following general issues should, however, be considered when selecting sections:

- Sections should be representative of the issue being investigated and results obtained from these sections should be representative of other roads with similar conditions.
- The establishment of the section should not pose a safety hazard to road users, or be so positioned that the safety of the persons monitoring the section is jeopardised.
- The road on which the section is being located should not be maintained, rehabilitated or resealed within the planned monitoring period, unless assessment of that intervention is part of the monitoring programme and prior warning is given to the LTPP Project Manager.
- Sections should be located as close as possible to traffic counting/weigh-in-motion stations, unless a station is incorporated into the section.

4.1.3 HVS-LTPP Sections

HVS sections are identified to study specific pavement performance/behaviour related issues as part of a longer-term research program and experimental designs are prepared for each experiment. The development of a general design matrix for identifying sections on various pavement types is therefore not applicable.

The LTPP section should be adjacent or as close as possible to the relevant HVS test section provided that the features (pavement structure and topography) of the LTPP section are uniform, representative of the HVS section and do not compromise the safety of the road user or LTPP investigators (Figure 4.1). Where any of the above conditions are not satisfied, the section may be up to 100 or 200 metres from the HVS section, but should be no further away than this. When selecting the HVS test section, factors that may have an impact on the successful monitoring of an adjacent LTPP section should be considered. For example the change from cut to fill would not have an impact on the short HVS section, but could have a significant impact on an LTPP section. Areas to avoid include cuts, high fill, sharp bends, large culverts, etc. The LTPP section should also be in the same lane (traffic direction) as the HVS section.

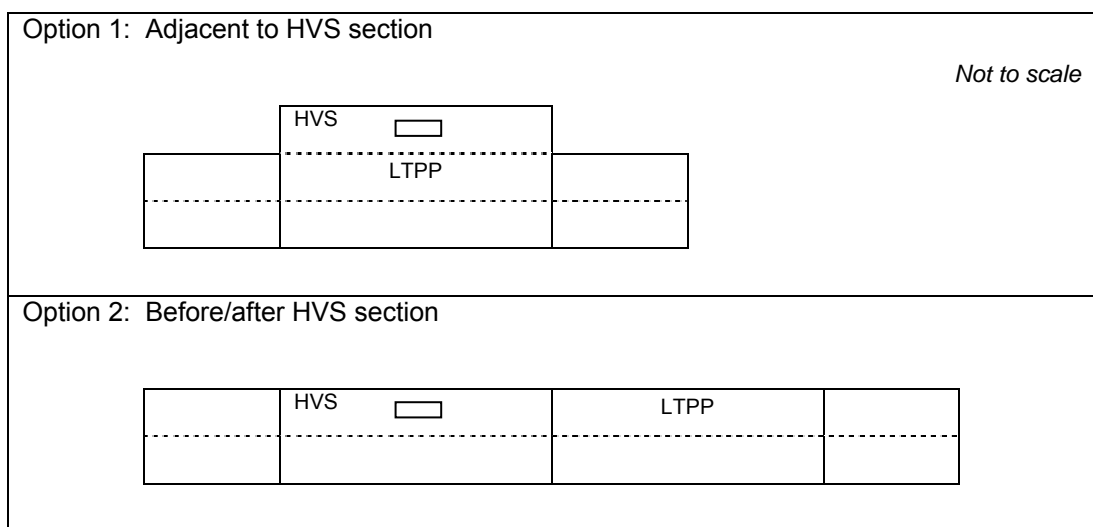

Figure 4.1: Options for location of LTPP sections

HVS Test Section Selection

HVS test sections are selected on the basis of pavement deflection measurements, as-built data and the structural characteristics of the specific test sections. Section identification is the responsibility of the project engineer, assisted by the HVS technician and in consultation with the project manager. The project manager and project engineer choose the frequency of deflection measurements, typically between one and three metre intervals as set out in the deflection measurement test programme. The Road Surface Deflectometer (RSD) is primarily used for deflection measurements, although Falling Weight Deflectometer (FWD) measurements may also be used.

Dynamic Cone Penetrometer (DCP) tests may also be used in the section selection to identify uniform areas and to give an indication of the pavement layer thickness. These measurements are used to validate as-built data or core measurements for positioning in-situ pavement monitoring instruments.

4.2. Section Numbering

Each LTPP section should be assigned a unique number for management purposes. No formalised numbering system is in place for LTPP sections in South Africa. The HDM calibration sections are currently identified simply by a Section number of 1 through 39. Although this is probably sufficient for staff directly involved in that study, additional information in the number would facilitate management and data retrieval. A centralised list should therefore be initiated, using the following format:

Type of LTPP section:	R (Routine), H (HVS), C (Calibration)
Section number:	Consecutive numbers in order of section adoption
Year:	Year of construction or commencement of monitoring
Province:	Province in which the section is located
Road number	
Example:	R1/03-G-P158/2 (The first routine section, constructed in 2003 in Gauteng on Road number P158/2) C1/93-L-P1/3 (Calibration section No1, identified in 1993, located in Limpopo on Road P1/3)

The chainage and direction of survey (positive or negative) should be linked to the section number in the database.

4.3. Section Layout and Marking

4.3.1 Existing Sections

The HDM calibration sections, on two-lane roads, are 500 m long and cover the entire road width including shoulders. On dual carriageways, the slow lanes, including shoulders, are monitored in both directions. Each section is subdivided into ten 50 m subsections. No destructive tests are carried out. The calibration sections are identified by signboards with section number and direction of survey. Subsections are located with a measuring wheel or tape. A typical layout is illustrated in Figure 4.2.

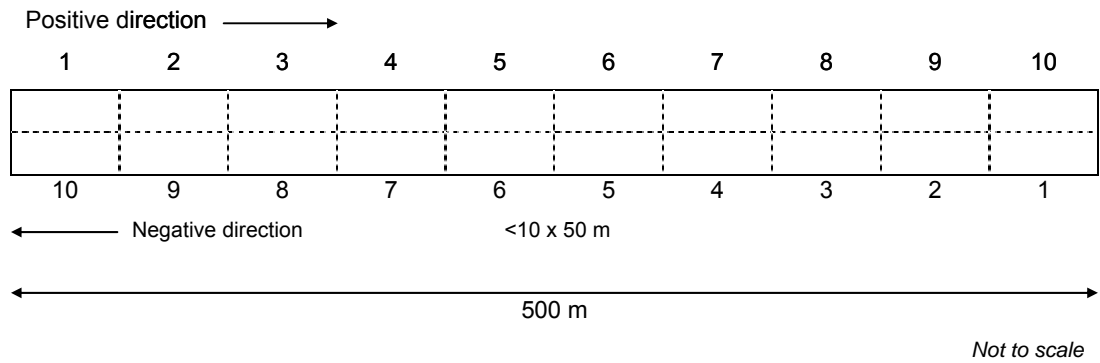

Figure 4.2: Layout of HDM calibration sections (two lane road)

No formalised section layout has been followed for other ad hoc LTPP sections or for the LTPP sections built adjacent to HVS test sections.

4.3.2 New Sections

The HDM calibration sections are 500 m long to allow a representative riding quality evaluation. However, monitoring long sections is a time consuming and therefore expensive undertaking. Therefore, a 200 m section is proposed for LTPP assessments, however, an additional 150 m should be demarcated on either side of the section for fuller riding quality assessments. Each 200 m section should be full-lane width and should consist of the following panels (Figure 4.3):

- 2 No 20 m panels (A and C) at either end for destructive testing (DCP, density and moisture content)
- 1 No 10 m panel (B) in the middle for destructive testing (DCP, density and moisture content)
- 10 No 15 m panels (1 -5 and 6 - 10) for general performance assessment

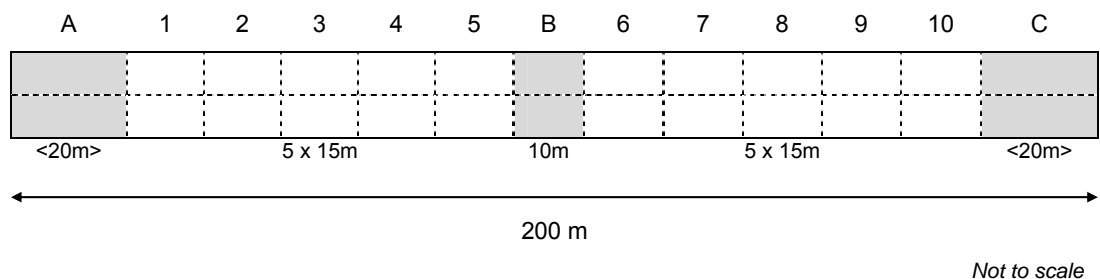

Figure 4.3: Layout of LTPP section (one lane width)

The GPS coordinates of the start of Panel A and end of Panel C of each LTPP section and the chainage at the beginning and end of each section should be taken and recorded

in the database to facilitate future location should the markings and/or signboards be removed.

Each LTPP section should be marked as follows:

- Signboards with the LTPP section number should be erected at either end of each section against the fence line. If two additional 150 m sections are incorporated for riding quality measurements, additional signs should be erected at the start and end point as well.
- Each section should be demarcated and numbered with white road marking paint as shown in Figure 4.4. Locator points for the RSD and FWD deflection measurements should also be painted. These are situated in Panels 1 to 10 in each wheel track and in Panels 2, 4, 7 and 9 midway between the wheel tracks as follows:
 - RSD - 5.0 m from the beginning of each Panel
 - FWD - 5.0 m from the end of each Panel (an RSD should be done at this site before the FWD test to check for consistency between the two sites and to calibrate the two testing techniques for that section)

A “map” of each section should be drawn after completion of the demarcation and filed at a central point to facilitate future assessments.

4.4. Instrument Installation

No LTPP sections, including the HDM calibration sections, are currently instrumented. Instrumentation on new LTPP sections will be experiment dependent, but should be considered in order to obtain useful data about the performance of the pavement.

Instrumentation on the LTPP section should be installed to the same standard as that specified for HVS test sections, by experienced and competent technicians. On HVS-LTPP sections, instrumentation should be installed at the same time as that on the HVS section.

Instrumentation will include Multi-depth Deflectometers (MDDs) and temperature buttons. In addition to the instrumentation, holes, lined with a thin aluminium tube, should be drilled and capped in Panels A, B and C for density measurements. A permanent weigh-in-motion apparatus should be installed after the section. Additional instrumentation can be installed at the discretion of the Project Director.

Instruments should be installed as follows (refer to Figure 4.5). Note that the outer wheel path is selected visually by the Project Manager, or taken as being 1.0 m from the road edge or shoulder marking if the position of the wheel-path is not clear.

- 3 No Multi-depth Deflectometers in the outer wheel path as follows:
 - Panel A - 1.0 m from boundary with Panel 1
 - Panel B - 1.0 m from boundary with Panel 5
 - Panel C - 1.0 m from boundary with Panel 10
- 9 No permanent holes for dual-probe hydrodensity meter in the outer and inner wheel tracks and on the centreline as follows:
 - Panel A - 5.0 m from boundary with Panel 1
 - Panel B - 5.0 m from boundary with Panel 5
 - Panel C - 5.0 m from boundary with Panel 10
- 3 No temperature buttons midway between the wheel paths and adjacent to the hydrodensity meter holes. The depths and reading frequencies will need to be decided by the Project Director and will depend on the pavement structure.
- 1 No Weigh-in-motion system within the first 100 m after the LTPP section, unless a permanent station already exists between the site and the next/previous intersection/off-ramp.

Guidelines ??

Instructions for calibration and installation of these instruments are provided in Appendix A.

4.5. Weather Station

A weather station comprising at least a thermometer (maximum and minimum) and a rain gauge should be erected as close as possible to the section. If the site is in a rural area, the most appropriate would be the closest farm. Measurements and reporting would have to be negotiated with the landowner. If the site is within a municipal boundary, then the closest official recording station can be used if no other suitable location can be found.

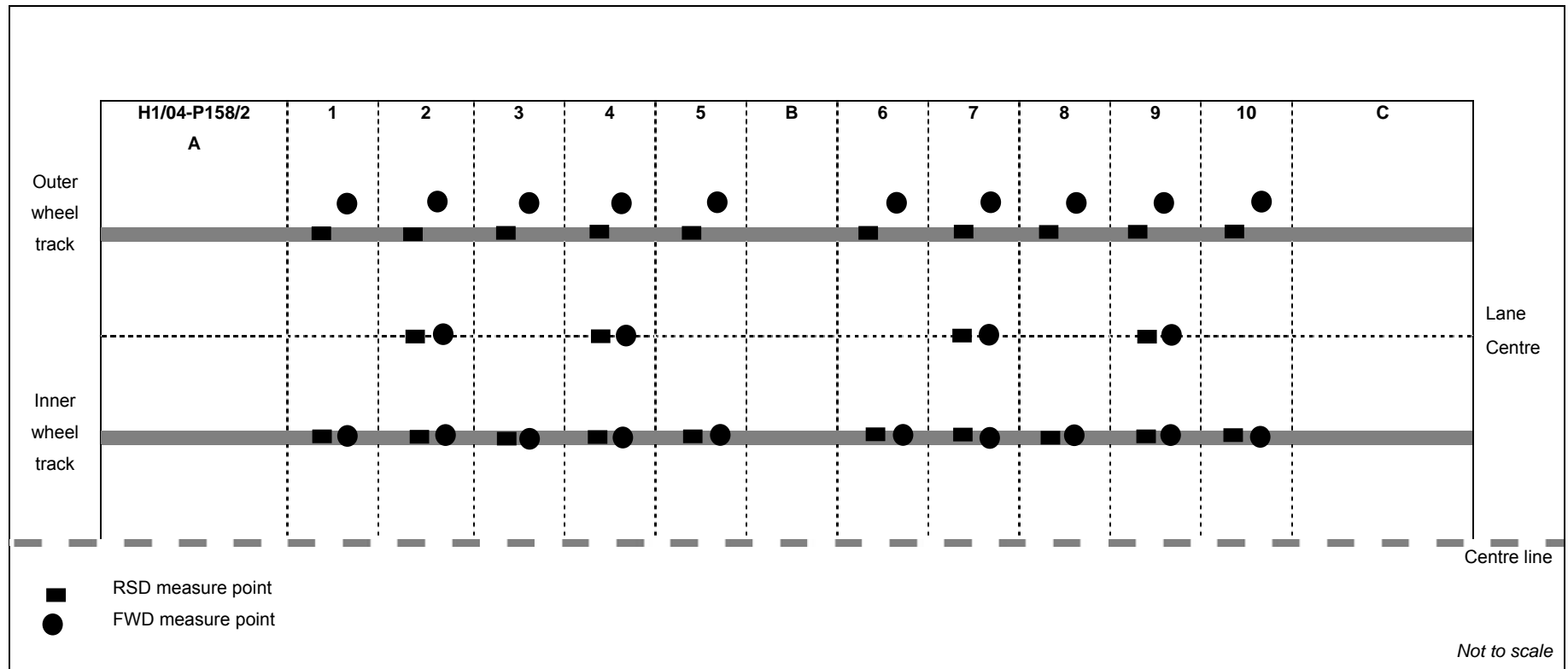

Figure 4.4: Section and measure point demarcation for LTPP sections

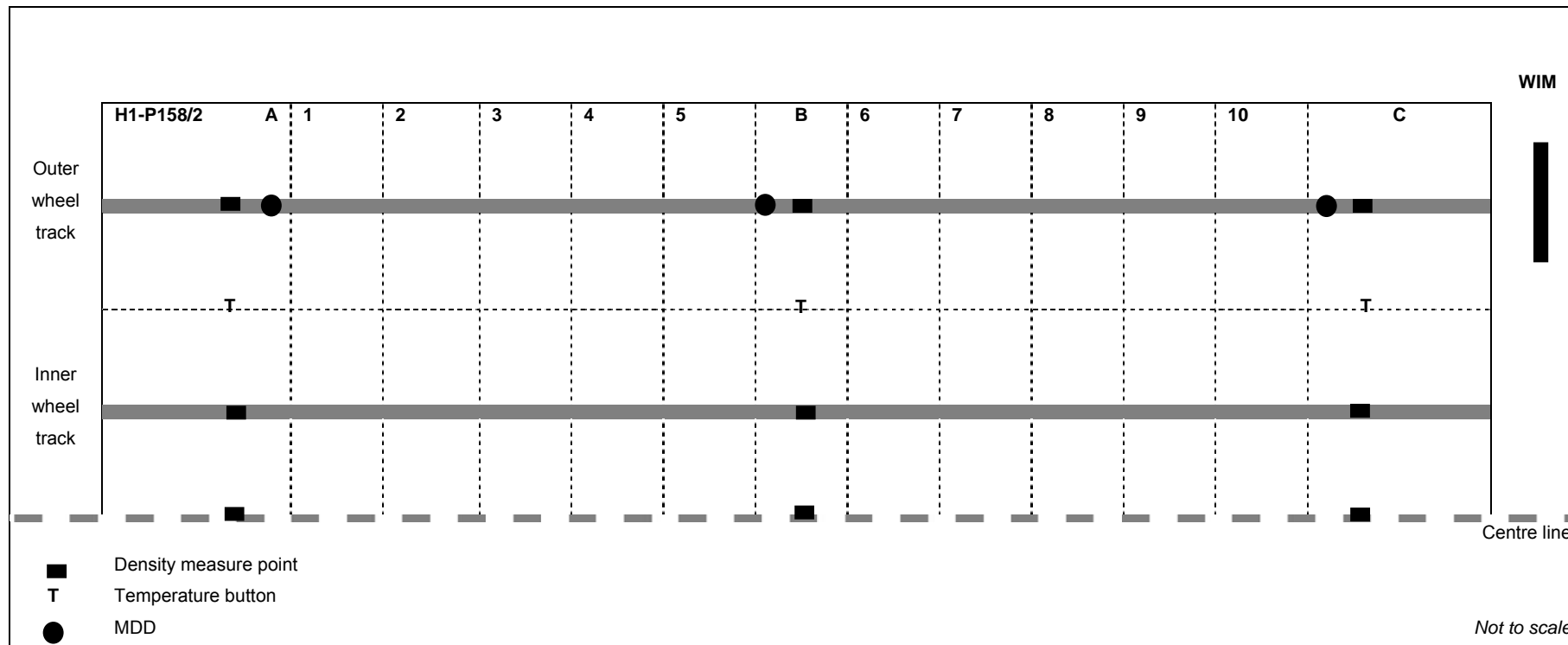

Figure 4.5: Instrumentation location for LTPP sections

5. DATA COLLECTION

5.1. Monitoring Standards

5.1.1 Visual Assessment

Visual assessments should be carried out on each panel according to the Gautrans Visual Assessment Manual for the calibration of HDM-III/IV² used in conjunction with TMH-9³. Results should be recorded on an LTPP Visual Assessment Form (Form 1 in Appendix B). Where the LTPP performance is linked to HVS tests, it is important to identify when the first cracks appear, the nature of the cracking and how the crack pattern changes over time. Crack patterns should be linked to a cause wherever possible (eg, change in deflection). Additional measurements as specified can also be taken to suit the needs of the experiment.

The Project Manger should calibrate the field technician assessors before each monitoring cycle (see TMH-9).

The following digital photographs should also be taken during each visit (preferably at the same time of day during each monitoring exercise):

- A general view of the road from both ends (photographer stands on the outer limit of Panels A and C in the middle of the lane)
- Two photographs of each panel taken from the start and end of each panel in the middle of the lane. A two metre straight edge should be laid across the road midway between the FWD and RSD wheel track monitoring points as a scale.
- Photographs of any specific distress details should also be taken using the 2.0 m straight edge, or part thereof as a scale. Notes on the photographs should be made in the Notes section on the Visual Assessment Form.

Output

Completed visual assessment form.

5.1.2 Transverse Profile

Transverse profile should be measured with a 2.0 m straightedge and 1.0 cm wedge. If available, the electronic straightedge² developed for the HDM calibration sections can also be used. The end of the straight edge should be placed in the marked centre of the lane, first in the direction of the road edge and then in the direction of the centreline, on each panel boundary. The following measurements should be taken:

- A profile of measurements every 100 mm from lane centre to road edge/centreline
- Maximum rut depth
- Rut width (measured with a tape measure).

Measurements should be recorded on the LTPP Profile Form (Form 2 in Appendix B).

Output

Completed transverse profile form.

5.1.3 Longitudinal Profile

Longitudinal profile should be measured with any instrument that provides an International Roughness Index (IRI) calibrated to specification for IRI. In South Africa, profile measuring equipment is calibrated on calibration sections, measured with rod-and level and against a Dipstick® profileometer. This instrument is also specified for longitudinal profile measurements in the United States US LTPP program.

The average IRI of three runs, two in the increasing direction and one in the decreasing direction should be recorded. The profile of both wheel paths should be measured.

Output

Average IRI for each wheel path in each panel. If the data is recorded electronically, it should be provided in spreadsheet compatible format.

5.1.4 Density and Moisture Content

Density and moisture content should be measured with a dual-probe hydro-density meter in permanent holes drilled and lined with a thin aluminium tube (1.0 mm) for this purpose in Panels A, B and C (see Figure 4.5). The holes must be sealed with an appropriate bung immediately after testing. Moisture contents measured with the hydro-density meter should be calibrated against a gravimetric moisture content sampled with a hand or power augur near the hole. Material representative of each layer should be sampled to the same depth as measurements taken with the hydro-density meter and the gravimetric moisture content compared with the recorded readings for at least the first six monitoring visits (ie three years) or until a satisfactory correlation has been obtained. The machine wet and dry densities and moisture content should be recorded for every 50 mm depth. These readings, together with the gravimetric moisture content and recalculated dry density should be recorded on the LTPP Density and Moisture Form (Form 3, Appendix B).

In order to ensure that there is no long-term influence on the moisture regime or density around the HDM holes, care must be taken in selecting the sampling sites (recommended

at least 1.0 m from the hydro-density meter hole in a circular pattern). The holes must be reinstated with shoulder gravel and tamped with a suitable rod and then the upper 30 mm sealed with cold mix asphalt.

Detailed instructions on the measurement of density and moisture are provided in Appendix A.

Output

Completed Density and Moisture Content Form. Note that this form is only considered complete when the gravimetric moisture content and recalculated dry density have been entered.

5.1.5 Dynamic Cone Penetrometer (DCP)

DCP measurements should be taken approximately 1.0 m from the density/moisture content sampling areas in Panels A, B and C. Measurements should be recorded at 5-blow intervals to a depth of 800 mm. Cemented layers should be drilled if no penetration with the DCP is obtained. DCP tests should be done within 1.0 m of the HDM holes and subsequent tests should be carried out at least 1.0 m from existing sealed holes. Disposable cones should be used to prevent excessive disturbance during extraction of the apparatus. The use of disposable cones also reduces the chance that damaged cones will be used. However, cones should always be checked prior to the test being carried out. All DCP holes should be sealed with cold-mix asphalt (at least a 30 mm plug). Where significant differences in the three profiles occur, a duplicate set of tests should be carried out.

Results should be recorded on the LTPP DCP Form (Form 4, Appendix B).

Output

Completed DCP form.

5.1.6 Environment

Environment assessment will entail:

- Capturing weather details (daily rainfall, maximum and minimum temperature) recorded near the section or from a local weather station (Data captured on LTPP Weather Detail Form (Form 5 Appendix B))
- A visual assessment of the drainage of water from the road and away from the road according to TMH-9³ (captured on the Visual Assessment Form)
- Downloading pavement temperature from the temperature buttons (temperature intervals of 120 minutes). This entails removing the button, downloading the

information into a computer and then replacing the button. Data should be transferred to a spreadsheet before being submitted.

If recycled materials or non-traditional chemical additives are used in the road, additional environmental testing of the impacts on ground and surface water, soil and adjacent vegetation will have to be assessed according to a protocol developed specifically for the material being assessed. No protocol for environmental monitoring of LTPP and APT sections is currently available.

Output

Completed Weather Detail Form, Visual Assessment Form and spreadsheet of pavement temperatures.

5.1.7 Deflection

Deflection should be measured with both RSD and FWD at each of the points described in Section 4.4. The procedure for calibrating, taking and recording RSD measurements is detailed in Appendix A. Data is captured electronically. The procedure for FWD measurements will be instrument specific, but must be available for scrutiny. Both instruments must be calibrated according to the specification provided with the instrument, on the same section of road (RSD followed by FWD), with details of the calibration and name of calibrator included on the result form.

The following load properties should be used:

- Plate pressure/drop height: 550 kPa
- Plate diameter: 150 mm
- Sensor offset positions: 0, 200, 300, 600, 900, 1 200 and 1 500 mm
- Load impulse: half sine 25 - 30 millisecond

Output

Spreadsheet with the following data:

- Instrument
- Panel number
- Position
- Load data
- Pavement and air temperature
- Peak deflection
- Deflection at offsets

5.1.8 Permanent Deformation of Pavement Layers

Permanent deformation should be determined from the multi-depth deflectometers (MDD) installed as prescribed (Section 4.4) in Panels A, B and C. Information should be downloaded and submitted in spreadsheet compatible format.

5.1.9 Traffic

Traffic data should be obtained from the nearest traffic counting station. Since traffic data is essential for the accurate modelling of pavement behaviour, the installation of permanent weigh-in-motion systems in the vicinity of the LTPP section, as prescribed in Section 4.4, is strongly recommended. The following minimum traffic data needs to be recorded:

- Number of vehicles
- Number of vehicles per weight classification (2 tonne intervals)
- Number of axles per vehicle
- Mass of each axle for vehicles with axle mass greater than 2 tonnes
- Distribution of vehicles with axle mass greater than 2 tonnes
- Vehicle speed
- Vehicle length
- Cumulative equivalent standard axles (E80's)

Tyre pressures on heavy vehicles should be recorded at existing weigh bridges at regular intervals and captured in the database.

Output

Summary of data on a monthly basis in spreadsheet compatible format.

5.1.10 Test Pits

Test pits should only be excavated on LTPP sections to assess the cause and attributes of major failures that require rehabilitation, when the road is scheduled for reconstruction or rehabilitation or at the end of the LTPP study. The size and depth of the test-pit will depend on the attributes being assessed. Pits should be profiled immediately after excavation.

The test pit profiles should be fully described according to the Jennings, Brink and Williams standard⁴. However, additional information on the nature of the interlayer boundaries (deviations and conditions, eg ruts and cracks) should also be included. For cemented layers, it will be important to assess the in-situ condition of the stabilized layer. This is best done using a phenolphthalein spray. Observations should be recorded on an LTPP Test Pit Form (Form 6, Appendix B).

Samples should be removed from each layer in both wheel tracks and the centreline. Sufficient sample should be removed to satisfy the requirements of the tests that will be carried out. If failures are being investigated, material from the failed area in the layer should be sampled.

If test pits are excavated during the service life of the road for any reason, they should be carefully reinstated using material and layer thicknesses conforming as closely as possible to those in the road. Careful sealing of the surface, to prevent the ingress of water and inducement of axle hop, must be carried out.

Although it is suggested that test pits are excavated at the start of the monitoring to check layer thicknesses, the cost and disruption caused by these makes it more appropriate to use the DCP profiles to determine the layer thicknesses. These will be confirmed later in the monitoring by test pits.

Output

Completed LTPP Test Pit Form

5.2. Sampling and Reinstatement

Samples should only be removed from Panels A, B and C. If a significant failure occurs in one of the other panels, a test pit can be excavated for investigation purposes. That panel should then be excluded from further evaluations, but the repair should be of such quality that it does not affect the performance of adjacent sections.

All sample holes and test pits must be properly reinstated. This will include:

- Replacing similar material to that excavated from each layer and compacting it to the specified thickness and density
- Effectively sealing the excavation ensuring that no water can penetrate into the base
- Levelling the surface of the patch such that the riding quality of the section is not affected and that dynamic bounce in vehicles that may affect the adjacent sections is not introduced
- Monitoring the patches on all subsequent visits to ensure that water is not penetrating the patch and that the patch is still level with the surrounding surface

5.3. Monitoring Program

Each section should be monitored at six monthly intervals, in May and October. More frequent assessments can be made if required, once distress/failure is initiated.

The HDM calibration sections are currently assessed on an annual basis at the end of the dry season (August/September in Gauteng). FWD measurements were taken at project initiation and after approximately five years. No plan for regular FWD measurements is in place.

5.4. Laboratory Testing

Laboratory testing is an integral component of APT and LTPP programs and is carried out to fully understand the characteristics of the pavement material. It is essential that the properties of the material at time of construction (or section initiation) are fully identified and recorded to allow comparison over time. As built records are unlikely to provide the level of data required. Laboratory testing should be carried out in an accredited laboratory.

Testing programs should be initiated at the following intervals:

- Pre-construction/rehabilitation
- Post construction/rehabilitation
- In service (approximately half way through design life of experiment or pavement)
- Rehabilitation/end of service

Details on the tests for LTPP sections are listed in Tables 5.1 to 5.4. For experimental monitoring, specific additional properties may need to be assessed, depending on the application.

Testing, such as durability and C and Φ is generally only applicable to base and sometimes subbase and will not be necessary for other layers. The durability testing method would need to be adapted for the material being assessed (eg glycol soaking for basic crystalline rocks and Venter Slake Test for mudrocks).

It is important that as much testing as can be practically done is carried out during the pre-construction and construction period as it is usually not possible to obtain representative samples of the unprocessed material at a later date. For this reason, it is

also suggested that a control sample is collected and carefully stored for possible later testing. Representative samples should be removed from each layer.

Table 5.1: PRE CONSTRUCTION DESIGN

RECOMMENDED LABORATORY TESTING FOR LTPP MONITORING							
SURFACING			BASE / SUBBASE				
			TREATED			GRANULAR	CRUSHED STONE
ASPHALT HMA	SEALS	CONCRETE	CEMENT / LIME	BITUMEN	OTHER		
<i>Aggregate</i>	<i>Aggregate</i>	<i>Aggregate</i>	Grading	Grading	Grading	Grading	Grading
Grading	Grading (dust content)	Grading (dust content)	GM	GM	GM	GM	GM
ACV or 10% FACT	ACV or 10% FACT	10% FACT Dry / Wet	PI	PI	PI	PI	PI
Water absorption	ALD	ACV	Liquid Limit	Liquid Limit	Liquid Limit	Liquid Limit	ACV
Flakiness Index	PSV	Fineness Modulus	Plastic Limit	Plastic Limit	Plastic Limit	Plastic Limit	10% FACT
Sand equivalent	Flakiness Index	Flakiness Index	Linear Shrinkage	Linear Shrinkage	Linear Shrinkage	Linear Shrinkage	Liquid Limit
<i>Binder</i>	<i>Binder</i>	Water Absorption	Sand Equivalent	Sand Equivalent	Sand Equivalent	Sand Equivalent	Plastic Limit
Penetration at 25°C	Penetration at 25°C	Sand Equivalent	Initial Consumption of Lime	MDD	MDD	MDD	Linear Shrinkage
Softening Point °C	Softening Point °C	Organic Impurities	Initial Consumption of Cement	OMC	OMC	OMC	Flakiness Index
Viscosity at 40°, 60°, 135°, 165°, 190°C	Viscosity at 60°, 135°, 165°, 190°C	Soundness	MDD	CBR	CBR	CBR	Soluble Sants
After RTFOT mass change %	Ductility / Force Ductility at 15°C	Chloride Content	OMC	UCS	UCS		pH and Conductivity
Spot Test	After RTFOT mass change %	Presence of Sugar	CBR	Optimum Fluid Content			Apparent Relative Density
Rubber Particle Size / Grading	Rubber Particle Size / Grading	Soluble Salt	UCS	Initial Consumption of Cement			Water Absorption
Rubber Density	Rubber Density	Cly Content	ITS	Initial Consumption of Lime			Brutto Relative Density
Rubber Polymer Content	Rubber Polymer Content	<i>Concrete Mix</i>	Wet-dry durability	Foam Index			Mineralogy
Rubber Resilience	Extended Oil Compositional Analysis (Saturates, Aromatics, Asphaltenes)	Max Water / Cement Ratio	Accelerated Carbonation	Resilient Modulus			
Extended Oil Compositional Analysis (Saturates, Aromatics, Asphaltenes)	Blending Reaction Temperature °C	Min Cement Content	E-modulus				
Blending Reaction Temperature	BR Compression Recovery after 5min 1hour 4 days	Slump of freshly mix concrete					
BR Compression Recovery after 5min 1hour 4 days	BR Resilience %	Compressive Strength					
BR Resilience %	BR Flow	Air Content					
BR Ring and Ball	BR Elastic Recovery at 15°C	Flexural Strength					
BR Flow	Complex Shear Modulus						
Ductility / Force Ductility at 15°C	Creep Stiffness (BBR)						
Elastic Recovery	Stability (Difference in R&B at 160°C						
Storage Stability	Adhesion 5°C						
Complex Shear Modulus	Soaybolt Viscosity						
Creep Stiffness (BBR)	Emulsion Residue on Sieving						
Torsional Recovery at 25°C	Ball Penetration on road						
<i>Mix</i>	Sand Patch (Texture depth)						
Binder Content							

Table 5.2: Construction Stage

RECOMMENDED LABORATORY TESTING FOR LTPP MONITORING							
SURFACING			BASE / SUBBASE				
ASPHALT HMA	SEALS	CONCRETE	TREATED			GRANULAR	CRUSHED STONE
			CEMENT / LIME	BITUMEN	OTHER		
Binder Content	Viscosity	<i>Aggregate</i>	Grading	Grading	Grading	Grading	Grading
Grading	Softening Point	Grading	PI	PI	PI	PI	PI
Stability & Flow	Binder application Rate	10% Fact or ACV	Liquid Limit	Liquid Limit	Liquid Limit	Liquid Limit	Liquid Limit
Bulk Relative Density	Aggregate Application Rate	<i>Mix</i>	Plastic Limit	Plastic Limit	Plastic Limit	Plastic Limit	Plastic Limit
Max Theoretical Relative Density	Binder Temperature	Slump of freshly mix concrete	Linear Shrinkage	Linear Shrinkage	Linear Shrinkage	Linear Shrinkage	Linear Shrinkage
Dynamic Creep	Penetration	Compressive Strength	Sand Equivalent	MDD	MDD	MDD	Flakiness Index
Cores Density	Resilience Binder Content (Emulsion)		MDD	OMC	OMC	OMC	Water Absorption
Temperature	BR Flow		OMC	UCS	UCS	CBR	Apparent Relative Density
	BR Blending reactivity temperature		UCS	ITS	ITS	Field Density	Field Density
	BR Compression recovery after 5 min 1 hour 4 days		ITS	Cement Content	Field Density		
	BR Resilience %		Cement / Lime Content	Binder Content			
	BR Ring and Ball		Field Density	Field Density			
	Road Surfacing Temperature						
	Air Temperature						

Table 5.3: Performance in service

RECOMMENDED LABORATORY TESTING FOR LTPP MONITORING							
SURFACING			BASE / SUBBASE				
			TREATED			GRANULAR	CRUSHED STONE
ASPHALT HMA	SEALS	CONCRETE	CEMENT / LIME	BITUMEN	OTHER		
Skid Resistance	Skid Resistance	Skid Resistance	DCP	DCP	DCP	DCP	DCP
Texture Depth	Texture Depth	Riding Quality	FWD	FWD	FWD	FWD	FWD
Riding Quality	Ball Penetration	Compressive Strength	Pit Tests	Pit Tests	Pit Tests	Pit Tests	Pit Tests
Water Permeability	Riding Quality	Flexural Strength					
Binder Content							
Grading							
Density							
Binder Penetration							
Softening Point							
Compositional Analysis (Asphalts, Resins, Saturates, Aromatics)							

6. REPORTING CRITERIA

All field monitoring and test data should be transferred to a set of clean forms, checked by the Field Technician and then the Project Manger before being presented to the Database Manager within 10 days of the assessment. Any accompanying laboratory test data should be completed and handed in together with the field data.

Other incidental laboratory testing associated with failures or rehabilitation/repairs will usually take longer, but should be collated and checked before being submitted to the Database Manager, as soon as possible after testing has been completed.

The database must be kept up to date with all available information. This information must be in the current software format and all data must be backed up in the same format. Past backups must all be updated along with any revisions of software or software version.

6.1. First Level Analysis

A first level analysis should be carried out after each monitoring, with plots between selected performance criteria (eg, peak deflection, IRI, rutting, rut depth) and environmental properties (eg traffic and rainfall).

6.2. Second Level Analysis

A second level analysis should be carried out every two years and should include:

- An evaluation of the structural behaviour
- The identification of any extraneous effects
- The development and refinement of performance prediction models
- On HVS-LTPP sections, the relationship between LTPP and HVS performance for similar traffic loading periods

The ultimate objective of the analysis over time will be to establish key linkages between ATP and LTPP results and develop models to predict the performance of the road as recorded in the LTPP monitoring. Accompanying HVS data can assist with this and/or can be extrapolated using the LTPP data to more accurately predict long-term performance.

7. REFERENCES

1. NETTERBERG, F and Haupt, F. 2003. Diurnal and seasonal variation of soil suction in five road pavements and associated pavement response. In: **The involvement of geotechnical engineering in infrastructure development in Africa**; edited by M Sahli, L Bahi and R Khalid, Marrakech: Megamix, pp 427-438.
2. **Visual assessment manual for the calibration of HDM-III/IV**. 2001. Pretoria: Gauteng Department of Transport and Public Works. (Report RNMS/H/49/E, 2nd Edition).
3. **Pavement management systems: Standard visual assessment manual for flexible pavements**. 1992. Committee of State Road Authorities. (Technical Methods for Highways, TMH9).
4. JENNINGS, J.E., Brink, A.B.A. and Williams, A.A.B. 1973. Revised guide to soil profiling for civil engineering purposes in South Africa. **The Civil Engineer**. January 1973, pp 3- 12.

APPENDIX A

INSTRUMENTATION

APPENDIX A: INSTRUMENTATION

A.1 Road Surface Deflectometer (RSD)

A.1.1 Description

The RSD is a modification of the Benkelman Beam and measures the elastic surface deflection of a pavement under the action of a wheel load. The RSD consists of a 3.0 m long beam, which is supported on two reference feet at one end and the measuring point on the other. A Linear Variable Displacement Transducer (LVDT) is located between these two points. The RSD is positioned in such a way that the reference feet stand outside the deflection bowl area and the measuring point lies between the dual rear wheels of the measuring vehicle (two axle, dual tyre (11x20x14PR @ 520 kPa) truck with 8.2 tonne load on the rear axle). The deflection under the measuring point is then measured by logging the movement of the LVDT at various distances. At the measuring point a setscrew is located with which the RSD is zeroed before measurement starts.

A.1.2 Calibration

The RSD should be calibrated on the calibration jig, supplied with the instrument, prior to each set of measurements to ensure that the measured values are a true reflection of the actual deflection bowl. The calibration procedure is as follows:

- i) Select a smooth level surface.
- ii) Place the measuring point of the RSD on the jig plate
- iii) Set the RSD (software) and jig dial gauge to zero
- iv) Wind jig to 0.1 mm on the dial gauge and check the reading is the same on the RSD software
- v) Repeat the test at 0.1 mm intervals to 1.0 mm

A.1.3 Measurement Method

RSD measurements are taken as follows:

- i) Position the RSD on the painted marks (point at which the elastic surface deflection is to be measured) in the outer wheel path of Panel 1
- ii) Position the truck ± 3.0 m from the end of the beam such that the beam lines up with the centre of the dual wheels
- iii) Start the test on the computer and reverse the test truck at creep speed ± 1.0 m past the measuring point, towards the reference feet of the RSD
- iv) Move the wheel back to the starting point (± 3 metres away)
- v) Check that the reading has been taken
- vi) Repeat the test three times

- vii) Repeat the test in each wheel track in each of Panels 1 to 10

A.1.4 Reporting

Peak deflection and deflection bowl are provided in electronic format.

A.2 Multi-Depth Deflectometer (MDD)

A.2.1 Description

The MDD consists of several modules with LVDTs, which are installed at various depths in the pavement. The MDD measures the elastic deflection and permanent deformation of the various layers in the pavement. The modules are installed at distances of not less than 150 mm apart inside a vertical hole in the pavement. Installation depths depend on the depths of the layers whose elastic deflection and permanent deformation are to be quantified and should be determined by the project engineer and project manager from DCP surveys, as-built data and/or test pits and cores as part of the HVS section design.

A.2.2 Installation

Installation of MDDs should be done as follows:

- i) Position marks for the MDDs should be painted on the outer wheel track 1.0 m from the end of Panel A and 1.0 m from the beginning of Panels B and C. A percussion drill and a specially designed drilling rig are used for drilling the holes, which are normally approximately 3.3 m deep and 36 mm in diameter. After each hole is drilled it is cleaned out with compressed air. A core drill should be used for the top 100 mm of the hole, especially if the pavement consists of asphaltic layers. Ream the top of the hole to a diameter of 90 mm and depth of 25 mm, or until the MDD top cap is level with the pavement surface after installation. Cut a 50 x 50 mm slot from the top of the hole to the road edge to accommodate the wiring.
- ii) Prepare the neoprene lining (0.08 mm thick neoprene rubber, formed round a stainless steel tube 33 mm diameter x 1 200 mm long) by covering the stainless steel tube with silicon grease placing then placing the rubber lining. Attach the aluminium bush with oil seal to the bottom end of the rubber lining.
- iii) Secure the anchor assembly in the hole with 200 ml of a mixture of cement and coarse river-sand in a ratio of 3 to 1.
- iv) Form the top cap with epoxy glue ensuring that it is positioned such that the screw holes in the top cap are in line with those in the cross section of the test section. The top cap must be left overnight for the epoxy to cure before the mould is removed.

- v) Mix the lining compound (2.0 l of Prostruct 34/40 and up to 300 ml xylene (depending on material) to liquidize the compound to a workable consistency, using a mixer connected to a hand drill) to secure the MDD anchor pin and the lining in the drilled hole. Pour the mixed liquid into the drilled hole, filling 50 per cent of the hole, to prevent air traps. Push the lining tube down into the hole while filling the hole with the remaining liquid. Use a neoprene cover around the hole to prevent spillage on the road surface. The lining compound will take between 12 and 48 hours to set, depending on the weather conditions (setting time increases with decreasing temperature). When set, remove the lining tube and cut the lining flush with the bottom of the top cap. Clean the lining with a cloth.
- vi) Fit the MDD snap connector onto the anchor pin using the supplied tool designed for this purpose.
- vii) Mark the MDD modules 1, 2, 3, etc. Ensure that each MDD slug has the same marks as its matching module. Do a final inspection on the modules to be used and check that all six securing ball bearings are fitted. Check that the cables are intact and properly soldered to each module.
- viii) Install the pilot rod (M5 brass rod, which is long enough to protrude ± 100 mm above surface) with the snap pin attached into the hole and ensure that the snap pin locks securely and positively in position. Write the depths at which the modules are located and the number of each module on the MDD information form. Clip the deepest installed module onto the MDD installation tool and mark on the tube of the MDD installation tool the desired depths of each module to be installed, using a marking pen. Measure from the centre of the securing ball bearings of the clipped on module to the prescribed depth. Guide the module to the deepest installed module position and with the MDD installation tool and pilot rod on the marked depth, secure the module with the MDD installation tool. Follow the same procedure with all the modules as required in this MDD hole. The sequence of modules is from the deepest, (with the highest number) to the shallowest, (No 1).
- ix) Feed the ribbon cables through the channels provided. The wires coming from levels 1, 2 and 3 modules on the module bodies are connected to the plug situated on the left-hand side of the top cap. The wires from levels 4, 5 and 6 are connected to the plug situated on the right-hand side of the top cap.
- x) Connect an installation unit to the MDD connections and check that every module is operating. This can be done with a dummy rod (M5 brass rod with length equal to the depth of the MDD hole and which has an MDD slug screwed onto its tip). While the rod is being pushed through the MDD modules fitted in the hole, the reading on the installation unit should be -13.00, 00.00, +13.00, as the slug on the dummy rod goes through each module.

- xi) Push another M5 rod with snap connector fitted into position in the hole until it clips into the snap connector. Mark the point at which the rod is flush with the surface of the test section with a marking pen or a strip of masking tape. Use the dummy rod to establish the position of the deepest MDD module by inserting it through the module until a zero reading is reached on the conditioner. Mark this depth with a marking pen or a strip of masking tape at the point on the road flush with the surface of the pavement. Repeat this operation with each module installed and mark each depth on the rod. Remove the marked rod from the MDD hole.
- xii) When assembling the MDD slug rod, attach a strip of masking tape on a flat working area. Place the rods on the working place alongside the masking tape. Mark the total depth from the dummy rod onto the tape. Mark the locations of the MDD slugs for each module as marked on the rod.
- xiii) With the markings on the strip of masking tape, assemble the MDD slug rod starting from the snap connector pin. Place the numbered slug of each MDD on its mark on the masking tape. Place the snap connector pin on the snap connector pin mark from the reference point and cut lengths of M3 brass threaded rod to connect the snap connector pin and each slug forming the MDD slug rod. Use M3 brass threaded taper ferrules to lock the lengths of rods into the slugs.
- xiv) Screw a ± 300 mm long rod onto the top slug. Do not lock with a ferrule, as the rod is used for handling the MDD slug rod and will be removed after completion of installation. Push the MDD slug rod into the MDD hole through the modules until it snaps on the snap connector on the anchor pin.
- xv) The final adjustments to the slug positions can be made, based on the readings on the different channels on the installation unit, in order to have the slug located in the correct position. Shortening of the rod results in positive readings and lengthening of the rod in negative readings.
- xvi) Once the correct readings are obtained, thread the wires into a conduit and embed it in the prepared slot with cold mix patching material. Bury the conduit in the road reserve and connect to a plastic box that will house the connector. Ensure that the box is sealed and secured.

Detailed tool and equipment lists are provided in the HVS Operations Protocol.

A.2.3 Calibration

After the installation of the MDD modules at the desired depths, the MDD must be calibrated. This will ensure that the measurements agree with the actual movement in the pavement. The HVS technician is responsible for the calibration of the MDD.

The following tools are required to calibrate the MDD modules fitted into an MDD hole:

- A calibration unit (part of the data acquisition software)
- A calibration jig fitted with a dial indicator mounted into a screw adjusting mechanism

The calibration process is as follows:

- i) Remove the snap connector pin from the MDD slug rod in order to facilitate free movement of the slug assembly. Move the MDD slug rod up and down to determine the mid (zero) position of the module (ie -13.00, 00.00, +13.00).
- ii) Place the calibrator unit above the MDD hole and connect the MDD slug rod with the calibrator unit. Turn the screw mechanism until the deepest module reads 0.00 on the conditioner unit.
- iii) Set the dial gauge on the screw mechanism to a zero reading and turn the screw mechanism until the reading is 7.5 mm on the dial gauge (using an E300 LVDT).
- iv) The same procedure is repeated for the calibration of the other modules. When the calibration procedures are complete replace the snap connector pin on the MDD slug rod and enter the final pot setting readings on the MDD information form.
- v) Do a final general inspection of the installation and connections and close the top cap.

A.2.4 Measurement Method

MDD measurements are downloaded into a data acquisition system.

A.2.5 Reporting

Permanent deformation and elastic deflection are provided in electronic format.

A.3 Temperature Buttons

A.3.1 Description

The temperature button is a computer chip enclosed in a 16 mm stainless steel casing that stores temperature data in a range between -10 and 85°C. It is designed to withstand harsh conditions.

A.3.2 Installation

Temperature buttons are installed as follows:

- Drill a 25 mm diameter hole to the required depth (typically bottom of the surfacing) in the required position (centre of the lane in Panels A, B and C)

- Place thin levelling layer of sand on the bottom of the hole
- Set temperature button to the required recording interval (120 minutes)
- Place temperature button in the bottom of the hole
- Seal the hole with cold mix filler, ensuring that there is no protruding aggregate

A.3.3 Calibration

Temperature buttons can be calibrated in hot water, by checking the temperature of the water and then immersing the button and checking the temperature recorded.

A.3.4 Measurement Method

Temperature buttons must be extracted from the pavement to download the data. This should be done carefully to prevent damage. Once removed, the data should be downloaded. The button can then be cleaned, calibrated and replaced in the hole.

A.3.5 Reporting

Data is captured electronically and presented in spreadsheet compatible format.

A.4 Dual Probe Hydro-density Meter

A.4.1 Description

The dual probe hydro-density meter (Strata gauge) is used to measure density and in-situ moisture content of the pavement structure. Measurements are recorded in 50 mm increments to a depth of 600 mm. The source material in the hydro-density meter is radioactive and although this does not pose a hazard to the operator under normal operating conditions, strict operating, maintenance and transport procedures, supplied with the equipment, must be followed at all times. Certain legal requirements in this regard must also be followed.

A.4.2 Calibration

The hydro-density meter should be calibrated on standard blocks according to the manual supplied with the instrument. Calibration blocks are available at the CSIR.

A.4.3 Measurement Method

The following procedure should be followed:

- i) Remove the cap of the predrilled holes.
- ii) Drop a 1.0 m x 10 mm wooden dowel into the hole to check for standing water/mud. If the holes have standing water/mud, new holes will have to be drilled 30 cm along the wheel track from the previous hole.

- iii) Measure the density and moisture at 50 mm intervals, starting at 600 mm, strictly following the specific operating and safety instructions provided with the gauge.
- iv) Record the information on the LTPP Density and Moisture Form (Appendix C).
- v) Reseal the holes.

A.4.4 Reporting

Density and moisture content are recorded on an LTPP density and moisture content form.

APPENDIX B

REPORTING FORMS

APPENDIX B: REPORTING FORMS

The following forms for the monitoring of LTPP sections are provided:

- Visual assessment (Form 1)
- Profile (Form 2)
- Density and moisture content (Form 3)
- Dynamic cone penetrometer (Form 4)
- Weather (Form 5)
- Test pits (Form 6)
- RSD Calibration (Form 7)
- MDD Calibration (Form 8)

Data for deflection, permanent deformation and traffic will be provided electronically in a spreadsheet or spreadsheet compatible format.

LTPP VISUAL ASSESSMENT FORM													Form 1					
LTPP Section		Panel			Date			Evaluator										
Surfacing assessment																		
Surfacing type																		
Texture		Varying		Fine		F - M		Medium		M - C		Coarse						
Voids		Varying		None		N - F		Few		F - M		Many						
		Degree					Extent					Length		Width	Number	Panels		
		Slight			Severe		Slight			Severe								
Mechanical failure		0	1	2	3	4	5	1	2	3	4	5						
Other failure		0	1	2	3	4	5	1	2	3	4	5						
Bleeding/flushing		0	1	2	3	4	5	1	2	3	4	5	Narrow	Wide		Position		
Surface cracks		0	1	2	3	4	5	1	2	3	4	5						
Binder condition		0	1	2	3	4	5	1	2	3	4	5	Active	Stable		Position		
Aggregate loss		0	1	2	3	4	5	1	2	3	4	5						
Structural assessment																		
		Degree					Extent					Narrow	Wide	Position	Panels			
		Slight			Severe		Slight			Severe		(% area)	(% area)					
Cracks - block		0	1	2	3	4	5	1	2	3	4	5						
Cracks - longitudinal		0	1	2	3	4	5	1	2	3	4	5						
Cracks transverse		0	1	2	3	4	5	1	2	3	4	5						
Cracks - crocodile		0	1	2	3	4	5	1	2	3	4	5						
Cracks - parabolic		0	1	2	3	4	5	1	2	3	4	5						
Pumping		0	1	2	3	4	5	1	2	3	4	5	Number		Diameter			
Rutting		0	1	2	3	4	5	1	2	3	4	5						
Undulation/settlement		0	1	2	3	4	5	1	2	3	4	5						
Edgebreak		0	1	2	3	4	5	1	2	3	4	5						
Potholes		0	1	2	3	4	5	1	2	3	4	5						
Delamination		0	1	2	3	4	5	1	2	3	4	5						
												Small	Medium	Large	Panels			
Patching		0	1	2	3	4	5	1	2	3	4	5						
Functional assessment																		
		Degree					Extent					Influencing factors						
		Slight			Severe		Slight			Severe								
Riding quality		0	1	2	3	4	5	1	2	3	4	5	Potholes	Patching	Undulation	Corrugate		
Skid resistance		0	1	2	3	4	5	1	2	3	4	5	Bleeding	Polishing				
Surface drainage		0	1	2	3	4	5	1	2	3	4	5						
Side drainage		0	1	2	3	4	5	1	2	3	4	5						
Notes																		

LTPP PROFILE ASSESSMENT FORM																	Form 2																									
LTPP Section		Panel			1 - 5			Date			Evaluator																															
Transverse	Panel A	Lane Centre															1.9	1.8	1.7	1.6	1.5	1.4	1.3	1.2	1.1	1.0	0.9	0.8	0.7	0.6	0.5	0.4	0.3	0.2	0.1	RE						
		Max rut																																								
		Width																																								
	Panel 1	Lane Centre															1.9	1.8	1.7	1.6	1.5	1.4	1.3	1.2	1.1	1.0	0.9	0.8	0.7	0.6	0.5	0.4	0.3	0.2	0.1	RE						
		Max Rut																																								
		Width																																								
	Panel 2	Lane Centre															1.9	1.8	1.7	1.6	1.5	1.4	1.3	1.2	1.1	1.0	0.9	0.8	0.7	0.6	0.5	0.4	0.3	0.2	0.1	RE						
		Max Rut																																								
		Width																																								
	Panel 3	Lane Centre															1.9	1.8	1.7	1.6	1.5	1.4	1.3	1.2	1.1	1.0	0.9	0.8	0.7	0.6	0.5	0.4	0.3	0.2	0.1	RE						
		Max Rut																																								
		Width																																								
	Panel 4	Lane Centre															1.9	1.8	1.7	1.6	1.5	1.4	1.3	1.2	1.1	1.0	0.9	0.8	0.7	0.6	0.5	0.4	0.3	0.2	0.1	RE						
		Max Rut																																								
		Width																																								
	Panel 5	Lane Centre															1.9	1.8	1.7	1.6	1.5	1.4	1.3	1.2	1.1	1.0	0.9	0.8	0.7	0.6	0.5	0.4	0.3	0.2	0.1	RE						
		Max Rut																																								
		Width																																								
	Longitudinal	Position	2.1	2.2	2.3	2.4	2.5	2.6	2.7	2.8	2.9	3.0	3.1	3.2	3.3	3.4	3.5	3.6	3.7	3.8	3.9	CL																				
		Outer	1		2		3		4		5		6		7		8		9		10																					
Inner																																										
Lane centre																																										

LTPP PROFILE ASSESSMENT FORM																	Form 2								
LTPP Section		Panel			6 - 10			Date			Evaluator														
Transverse	Panel B	Lane Centre			1.9	2.1	2.3	2.4	2.5	2.6	2.7	2.8	2.9	3.0	3.1	3.2	3.3	3.4	3.5	3.6	3.7	3.8	3.9	CL	RE
	Max Rut				1.8	2.2																			
	Width				1.7	2.3																			
					1.6	2.4																			
	Panel 6	Lane Centre			1.9	2.1	2.3	2.4	2.5	2.6	2.7	2.8	2.9	3.0	3.1	3.2	3.3	3.4	3.5	3.6	3.7	3.8	3.9	CL	RE
	Max Rut				1.8	2.2																			
	Width				1.7	2.3																			
					1.6	2.4																			
	Panel 7	Lane Centre			1.9	2.1	2.3	2.4	2.5	2.6	2.7	2.8	2.9	3.0	3.1	3.2	3.3	3.4	3.5	3.6	3.7	3.8	3.9	CL	RE
	Max Rut				1.8	2.2																			
	Width				1.7	2.3																			
					1.6	2.4																			
	Panel 8	Lane Centre			1.9	2.1	2.3	2.4	2.5	2.6	2.7	2.8	2.9	3.0	3.1	3.2	3.3	3.4	3.5	3.6	3.7	3.8	3.9	CL	RE
	Max Rut				1.8	2.2																			
	Width				1.7	2.3																			
					1.6	2.4																			
	Panel 9	Lane Centre			1.9	2.1	2.3	2.4	2.5	2.6	2.7	2.8	2.9	3.0	3.1	3.2	3.3	3.4	3.5	3.6	3.7	3.8	3.9	CL	RE
	Max Rut				1.8	2.2																			
	Width				1.7	2.3																			
					1.6	2.4																			
	Panel 10	Lane Centre			1.9	2.1	2.3	2.4	2.5	2.6	2.7	2.8	2.9	3.0	3.1	3.2	3.3	3.4	3.5	3.6	3.7	3.8	3.9	CL	RE
	Max Rut				1.8	2.2																			
	Width				1.7	2.3																			
					1.6	2.4																			
	Notes																								

LTPP DENSITY AND MOISTURE CONTENT ASSESSMENT											Form 3	
LTPP Section			Date			Evaluator						
Calibration	Prv	Std	Std	Std								
Std MC												
Std wet density												
	Probe	Input	Actual	Outer wheel path			Inner wheel path			Centreline		
				Wet	MC	Dry	Wet	MC	Dry	Wet	MC	Dry
Panel A	24	200	600									
	22	200	550									
	20	200	500									
	18	200	450									
	16	200	400									
	14	200	350									
	12	200	300									
	10	200	250									
	8	200	200									
	6	150	150									
	4	100	100									
	2	50	50									
Panel B	24	200	600									
	22	200	550									
	20	200	500									
	18	200	450									
	16	200	400									
	14	200	350									
	12	200	300									
	10	200	250									
	8	200	200									
	6	150	150									
	4	100	100									
	2	50	50									
Panel C	24	200	600									
	22	200	550									
	20	200	500									
	18	200	450									
	16	200	400									
	14	200	350									
	12	200	300									
	10	200	250									
	8	200	200									
	6	150	150									
	4	100	100									
	2	50	50									
Gravimetric moisture content												
	Sample depth	Tin No		MC	Actual dry		MC	Actual dry		MC	Actual dry	
Panel A												
Panel B												
Panel C												

LTPP DCP RECORDING SHEET								Form 4
LTPP Section		Panel	Date		Operator			
Outer wheel track		Inner wheel track				Centreline		
0		0			0			
5	205	405	5	205	405	5	205	405
10	210	410	10	210	410	10	210	410
15	215	415	15	215	415	15	215	415
20	220	420	20	220	420	20	220	420
25	225	425	25	225	425	25	225	425
30	230	430	30	230	430	30	230	430
35	235	435	35	235	435	35	235	435
40	240	440	40	240	440	40	240	440
45	245	445	45	245	445	45	245	445
50	250	450	50	250	450	50	250	450
55	255	455	55	255	455	55	255	455
60	260	460	60	260	460	60	260	460
65	265	465	65	265	465	65	265	465
70	270	470	70	270	470	70	270	470
75	275	475	75	275	475	75	275	475
80	280	480	80	280	480	80	280	480
85	285	485	85	285	485	85	285	485
90	290	490	90	290	490	90	290	490
95	295	495	95	295	495	95	295	495
100	300	500	100	300	500	100	300	500
105	305	505	105	305	505	105	305	505
110	310	510	110	310	510	110	310	510
115	315	515	115	315	515	115	315	515
120	320	520	120	320	520	120	320	520
125	325	525	125	325	525	125	325	525
130	330	530	130	330	530	130	330	530
135	335	535	135	335	535	135	335	535
140	340	540	140	340	540	140	340	540
145	345	545	145	345	545	145	345	545
150	350	550	150	350	550	150	350	550
155	355	555	155	355	555	155	355	555
160	360	560	160	360	560	160	360	560
165	365	565	165	365	565	165	365	565
170	370	570	170	370	570	170	370	570
175	375	575	175	375	575	175	375	575
180	380	580	180	380	580	180	380	580
185	385	585	185	385	585	185	385	585
190	390	590	190	390	590	190	390	590
195	395	595	195	395	595	195	395	595
200	400	600	200	400	600	200	400	600

LTPP WEATHER DETAIL RECORDING SHEET																	Form 5		
LTPP Section:				Year:			Recorded by:												
Day	January			February			March			April			May			June			
	Rain	Max	Min	Rain	Max	Min	Rain	Max	Min	Rain	Max	Min	Rain	Max	Min	Rain	Max	Min	
1																			
2																			
3																			
4																			
5																			
6																			
7																			
8																			
9																			
10																			
11																			
12																			
13																			
14																			
15																			
16																			
17																			
18																			
19																			
20																			
21																			
22																			
23																			
24																			
25																			
26																			
27																			
28																			
29																			
30																			
31																			
Total																			
Average																			

LTPP WEATHER DETAIL RECORDING SHEET

Form 5

LTPP Section:							Year:						Recorded by:					
Day	July			August			September			October			November			December		
	Rain	Max	Min	Rain	Max	Min	Rain	Max	Min	Rain	Max	Min	Rain	Max	Min	Rain	Max	Min
1																		
2																		
3																		
4																		
5																		
6																		
7																		
8																		
9																		
10																		
11																		
12																		
13																		
14																		
15																		
16																		
17																		
18																		
19																		
20																		
21																		
22																		
23																		
24																		
25																		
26																		
27																		
28																		
29																		
30																		
31																		
Total																		
Average																		

LTPP RSD CALIBRATION SHEET			Form 7
LTPP Section No:		Panel:	
Date:		Calibrated by:	
RSD ID No:		Level No:	
Dial gauge	Computer Up	Computer Down	Difference
0.0			
0.1			
0.2			
0.3			
0.4			
0.5			
0.6			
0.7			
0.8			
0.9			
1.0			
			Average
			Therefore mm/v = 1/average
Signature			

LTPP MULTI DEPTH DEFLECTOMETER CALIBRATION SHEET			Form 8
LTPP Section No:		Panel:	
Date:		Calibrated by:	
MDD No:		Level No:	
Dial gauge	Computer Up	Computer Down	Difference
0			
1			
2			
3			
4			
5			
6			
7			
8			
9			
10			
			Average
			Therefore mm/v = 1/average
MDD No:		Level No:	
Dial gauge	Computer Up	Computer Down	Difference
0			
1			
2			
3			
4			
5			
6			
7			
8			
9			
10			
			Average
			Therefore mm/v = 1/average
MDD No:		Level No:	
Dial gauge	Computer Up	Computer Down	Difference
0			
1			
2			
3			
4			
5			
6			
7			
8			
9			
10			
			Average
			Therefore mm/v = 1/average
Signature			